



# WHEA

Fire Compartments and Fire Door Requirements

# ASSA ABLOY - The global leader in access solutions

A light gray world map is centered in the background. Overlaid on the map are three blue circles, each containing a statistic. The first circle is positioned over North America, the second over Europe, and the third over Asia. The text inside the circles is white and bold.

Operations  
**70+**  
countries

Employees  
**49,000**

Sales USD  
**9.6**  
billion

**Ryan McLachlan, AHC, CFDAI, CM-BIM**  
Manager - Openings Studio Building Technologies

[Ryan.McLachlan@assaabloy.com](mailto:Ryan.McLachlan@assaabloy.com)  
(262) 825-3089

# Our non-residential product offering

Securing from the **perimeter...to shell...to core**

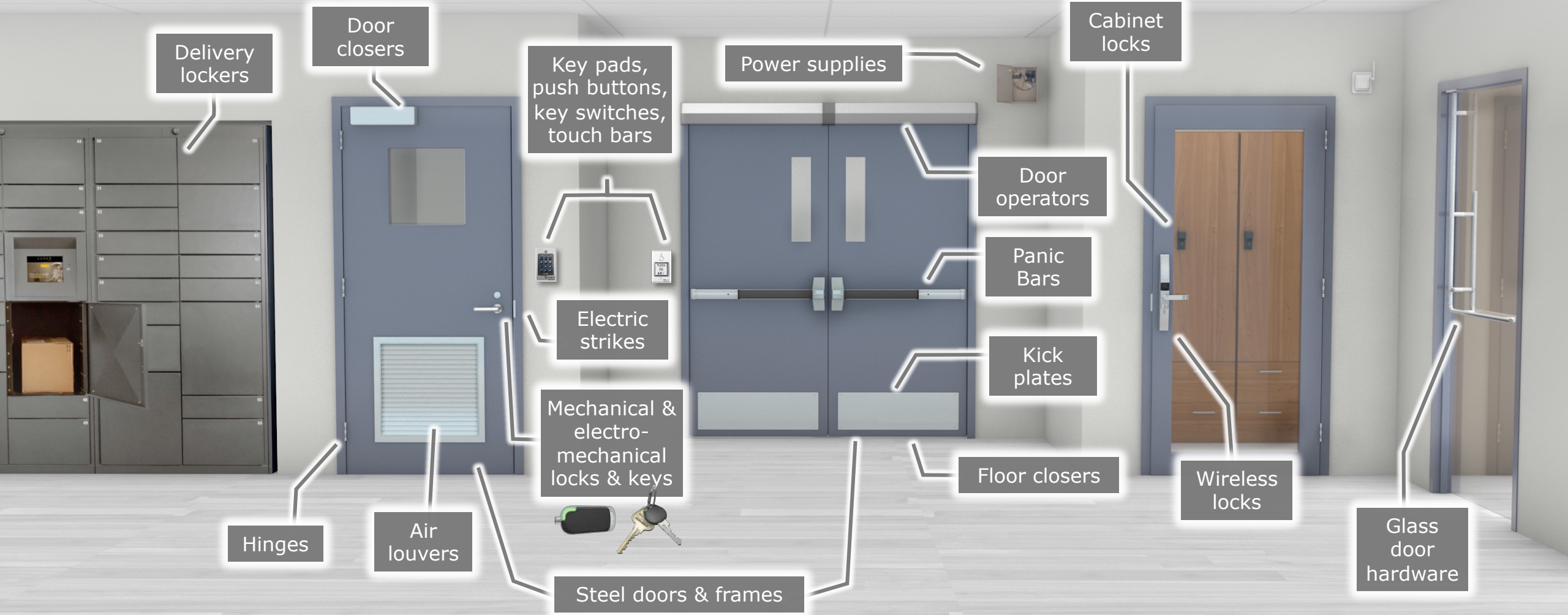

# Agenda

1. Passive fire protection systems
2. Annual fire door inspection requirements
3. How inspections are conducted
4. Common issues causing non-compliance
5. Reporting requirements
6. Remediation strategies



# What is Passive Fire Protection?

Building components designed to passively prevent or stop the spread of fire and smoke.

- **Structural Fire Protection**

- **Compartmentation**

- NFPA 101 – Life Safety Code:

- 8.2.2.1 Where required by other chapters of this Code, every building shall be divided into compartments to limit the spread of fire and restrict the movement of smoke.

- **Opening Protection**

- **Firestopping Systems**

- International Firestop Council  
[www.firestop.org](http://www.firestop.org)
- Firestop Contractors International Association  
[www.fcia.org](http://www.fcia.org)

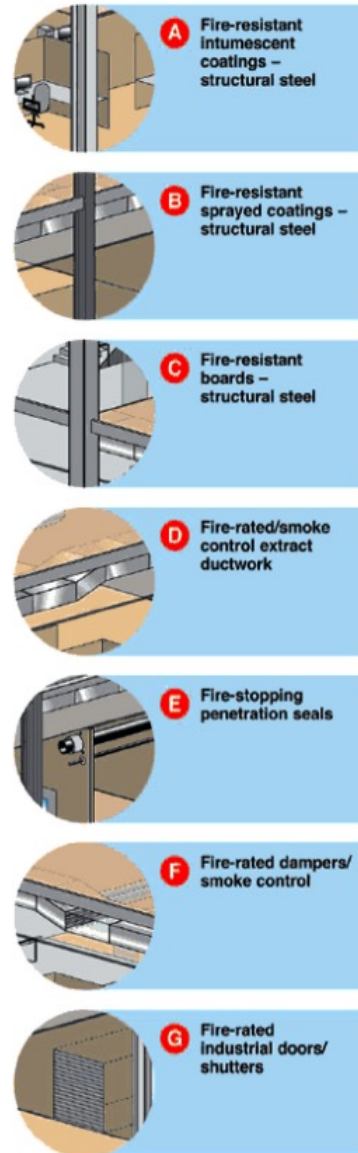

## IMPORTANT ASPECTS OF PASSIVE FIRE PROTECTION

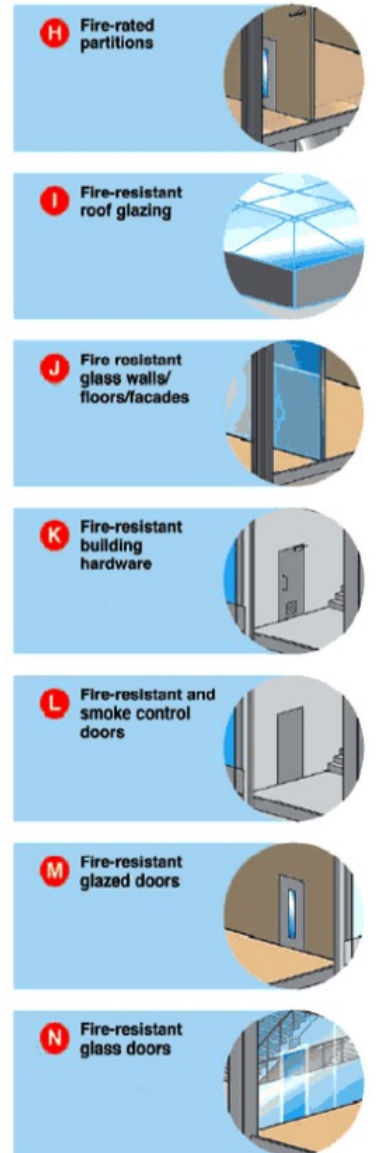
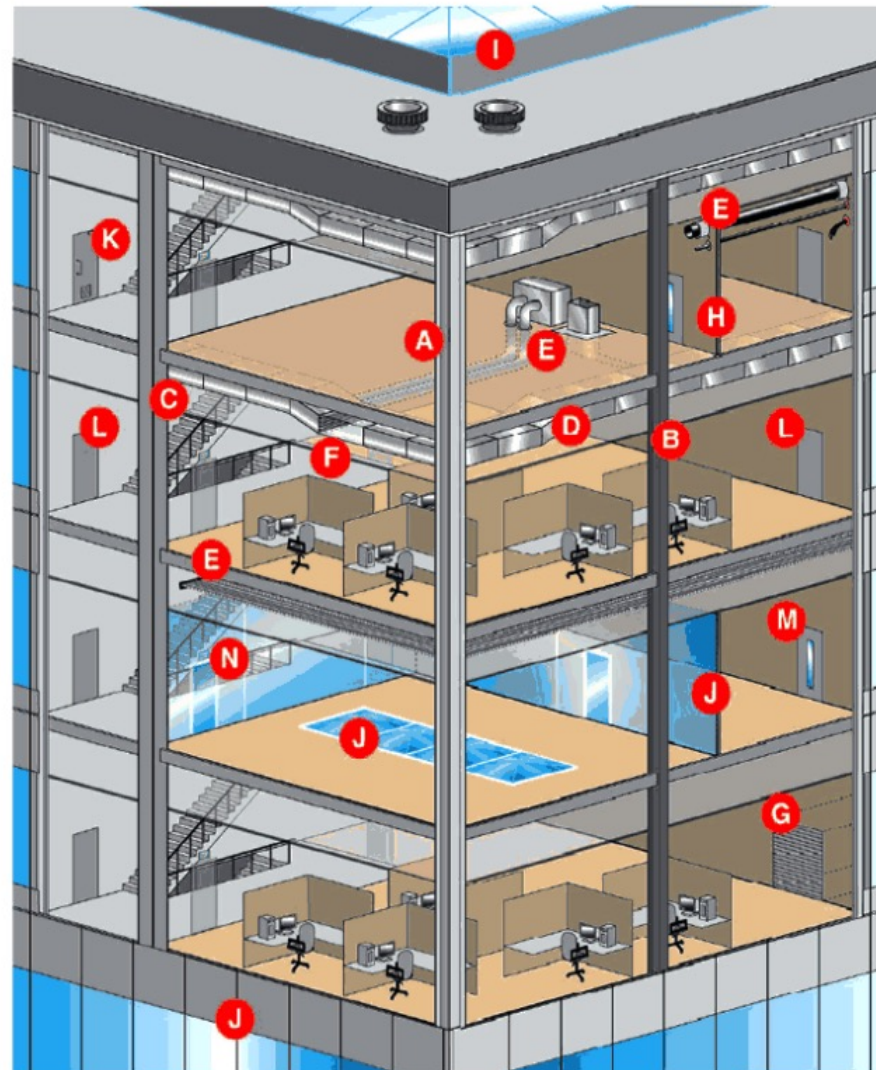

# What is Passive Fire Protection?

**TABLE 509  
INCIDENTAL USES**





ROOM OR AREA	SEPARATION AND/OR PROTECTION
Furnace room where any piece of equipment is over 400,000 Btu per hour input	1 hour or provide automatic sprinkler system
Rooms with boilers where the largest piece of equipment is over 15 psi and 10 horsepower	1 hour or provide automatic sprinkler system
Refrigerant machinery room	1 hour or provide automatic sprinkler system
Hydrogen fuel gas rooms, not classified as Group H	1 hour in Group B, F, M, S and U occupancies; 2 hours in Group A, E, I and R occupancies.
Incinerator rooms	2 hours and automatic sprinkler system
Paint shops, not classified as Group H, located in occupancies other than Group F	2 hours; or 1 hour and provide automatic sprinkler system
In Group E occupancies, laboratories and vocational shops not classified as Group H	1 hour or provide automatic sprinkler system
In Group I-2 occupancies, laboratories not classified as Group H	1 hour and provide automatic sprinkler system
In ambulatory care facilities, laboratories not classified as Group H	1 hour and provide automatic sprinkler system
Laundry rooms over 100 square feet	1 hour or provide automatic sprinkler system
In Group I-2, laundry rooms over 100 square feet	1 hour
Group I-3 cells and Group I-2 patient rooms equipped with padded surfaces	1 hour

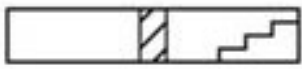
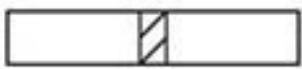

# What is a Fire Door Assembly?

A fire door assembly (installed in a firewall) is used as part of a passive fire protection system to reduce the spread of fire or smoke between compartments and to enable safe egress.

Table 1 – Fire door openings

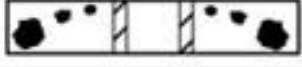
Opening	Wall Rating	Door and Frame Rating	Description and Use
	4 Hour	3 Hour (180 minutes)	These openings are in walls that separate buildings or divide a single building into designated fire areas.
	2 Hour	1-½ Hour (90 minute)	Openings of this type are used in enclosures of vertical communication or egress through buildings. Examples of these types of openings include stairwells and elevator shafts.
	1 Hour	1 Hour (60 minute)	These door and frame assemblies divide occupancies in a building.
	1 Hour	¾ Hour (45 minute)	For use where there are openings in corridors or room partitions.
	2 Hour	1-½ Hour (90 minute)	This opening is in a wall where there is the potential for severe fire exposure from the exterior of the building.
	1 Hour	¾ Hour (45 minute)	This opening is in an exterior wall that has the potential to be exposed to moderate to light fire from the exterior of the building.
	1 Hour	½ Hour (20 minute)	These openings are in corridors where smoke and draft control is required. The minimum wall rating is ½ hour.

# What is a Fire Door Assembly?

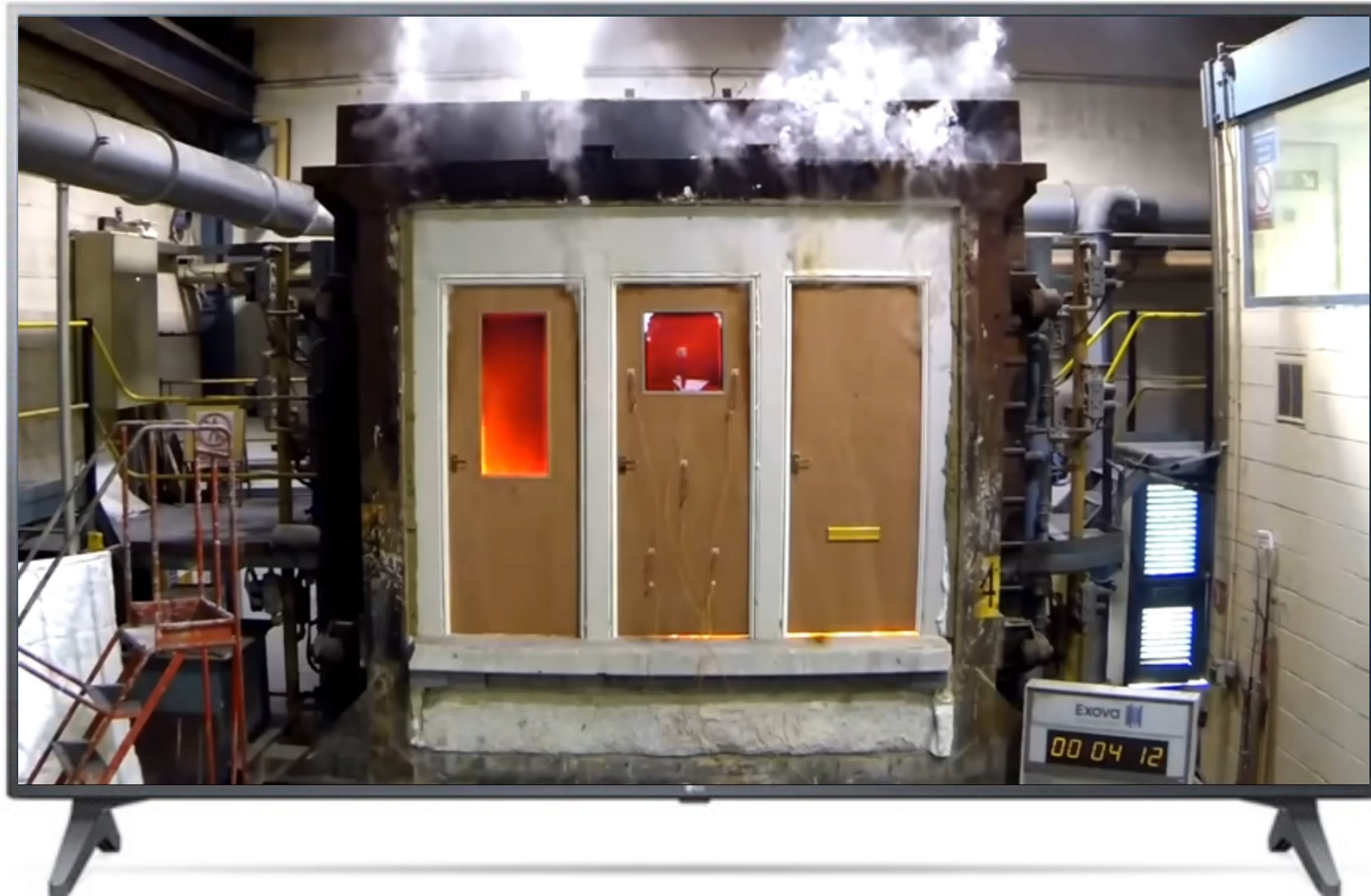

# Code Requirements

## Hammurabi Code - 1755 BC

- 229: If a **builder** builds a house for someone, and does not construct it properly, and the house which he built falls in and kills its owner, then that **builder** shall be put to death.



# Code Requirements

## NFPA 101 Life Safety Code – 2012

- Chapter 8 – Features of Fire Protection
  - **8.3.5 Penetrations**
  - **8.3.5.1 Firestop Systems and Devices Required**

Penetrations for cables, cable trays, conduits, pipes, tubes, combustion vents and exhaust vents, wires, and similar items to accommodate electrical, mechanical, plumbing, and communications systems that pass through a wall, floor, or floor/ceiling assembly constructed as a fire barrier shall be protected by a firestop system or device.

## NFPA 80 – 2010

- Chapter 19 – Installation, Testing and Maintenance of Fire Dampers
  - **19.4.1** Each damper shall be tested and inspected 1 year after installation.
  - **19.4.1.1** The test and inspection frequency shall then be every 4 years, except in hospitals, where the frequency shall be every 6 years.

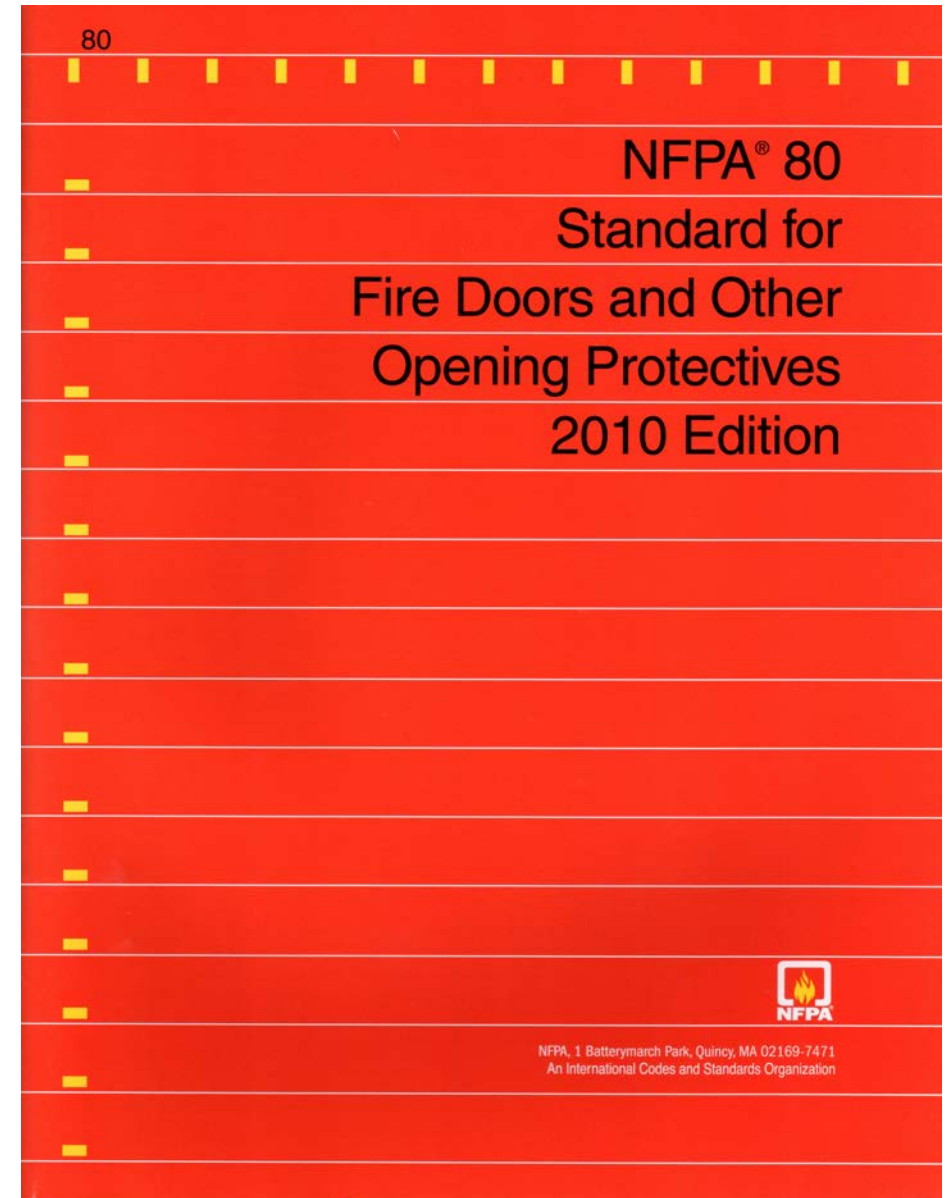

# Code Requirements

## Life Safety Code NFPA 101 – 2012

- Chapters 18 & 19 – Health Care Occupancies
  - References **7.2.1 Inspection of Door Openings**
  - **7.2.1.15.2** Fire rated door assemblies shall be inspected and tested in accordance with NFPA80, *Standard for Fire Doors and Other Protectives*. Smoke door assemblies shall be tested in accordance with NFPA 105, *Standard for Smoke Door Assemblies and Other Protectives*.

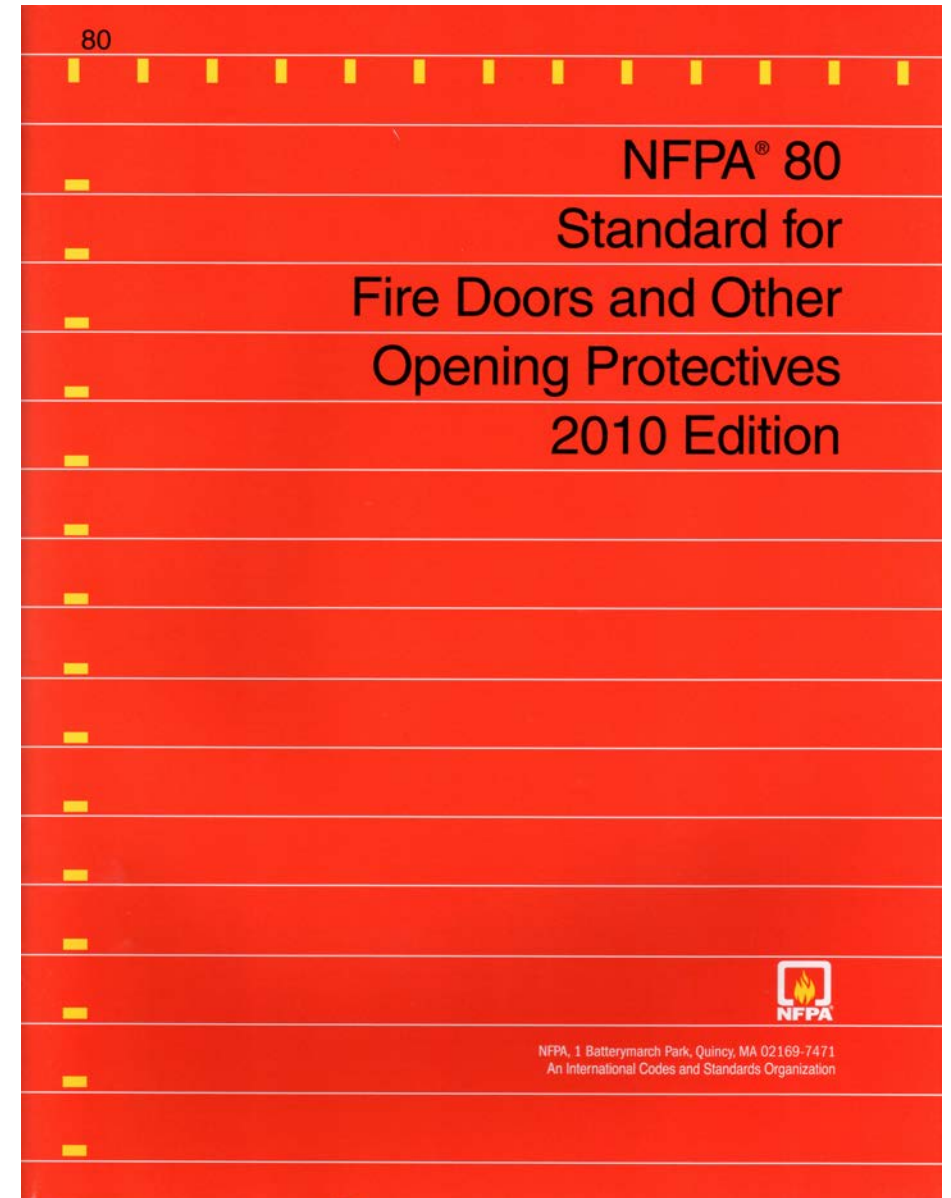

# CMS Requirements



## **New Life Safety Code business occupancy requirements for BHC organizations**

The Joint Commission is adding business occupancy standards to the Life Safety (LS) chapter for Behavioral Health Care and Human Services (BHC) organizations. This will go into effect on July 1.

# Code Requirements

## NFPA 80

- **5.2\* Inspection and Testing**
- **5.2.1\*** Upon completion of the installation, door, shutters, and window assemblies shall be inspected and tested in accordance with 5.2.4.
  
- **5.2.4 Periodic Inspection and Testing**
- **5.2.4.1\*** Periodic inspections and testing shall be performed not less than annually.

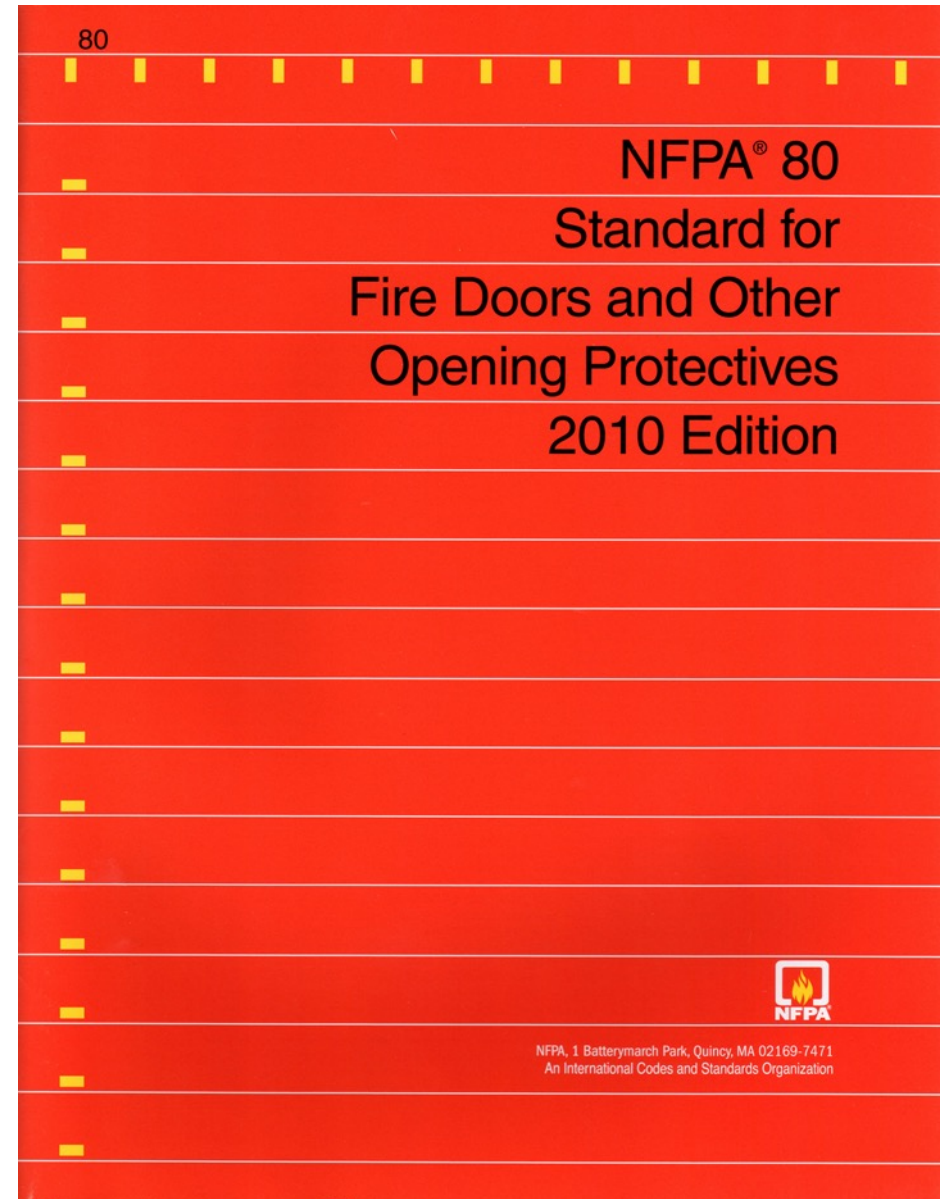

# Preparing for an Inspection – Life Safety Drawings

DAMPER KEY		LIFE SAFETY LEGEND	
FIRE		2-HOUR FIRE DAMPER	
SMOKE		1-HOUR FIRE DAMPER	
FIRE & SMOKE		4-HOUR FIRE DAMPER	
		BRICK BARRIER WALL (7' HIGH OR 6" MIN. CONCRETE PROTECTIVE)	
		BRICK PARTITION (SMOKE RESISTIVE) SOLID CORE WOOD DOOR	
		ESCAPE PATH AND DISTANCE	
		SAFE BOUNDARY	
		BRICK COMPARTMENT BOUNDARY	

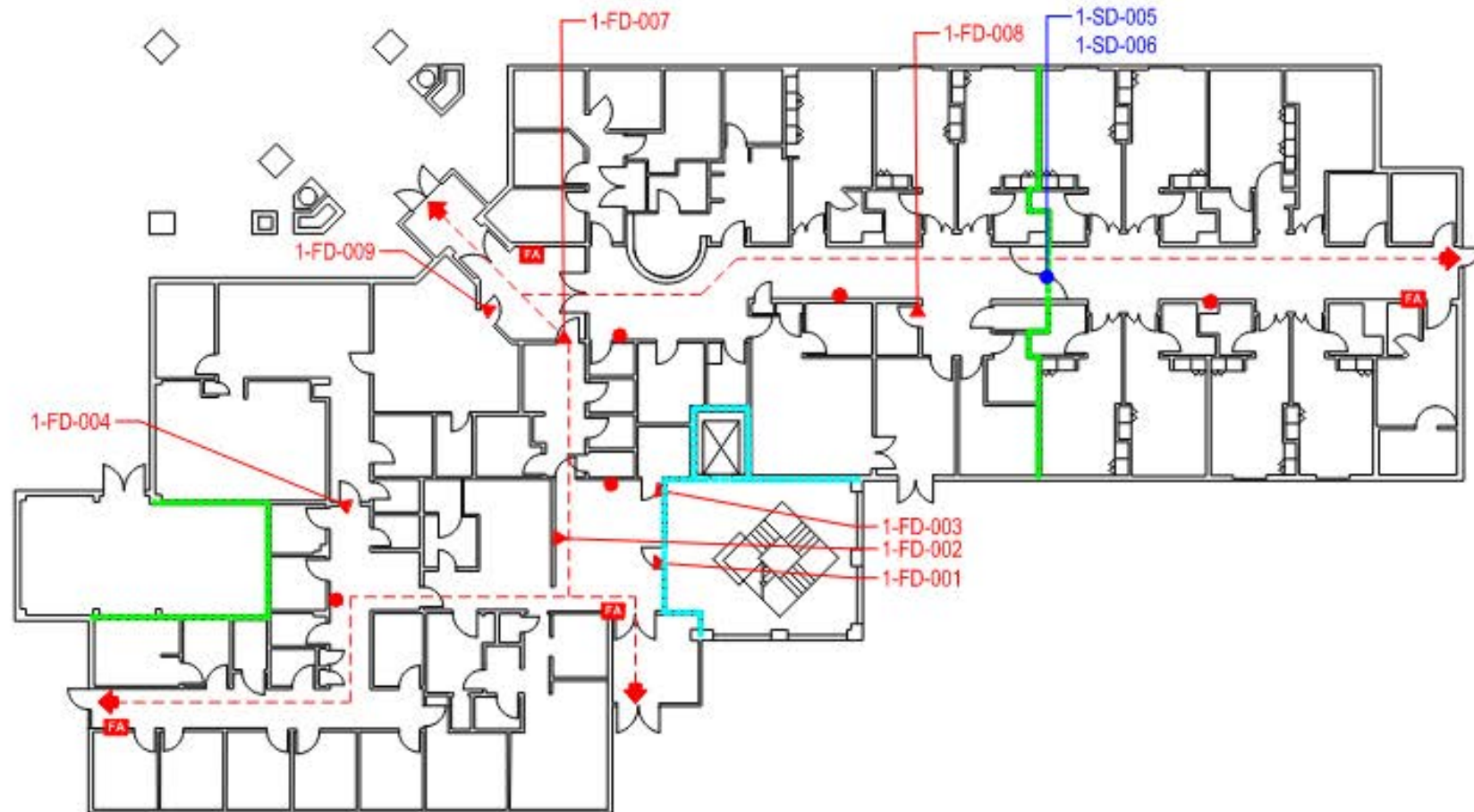

# Preparing for an Inspection

## NFPA 80

- **5.2.3 Acceptance Testing.**
- **5.2.3.1\*** Acceptance testing of fire door and window assemblies shall be performed by a qualified person with knowledge and understanding of the operating components of the type of assembly being subject to testing.



# NFPA 80 - 13 Points of a Fire Door Inspection

- **5.2.3.5.2** - As a minimum, the following items shall be verified:
  - **(1)** Labels are clearly visible and legible.
  - **(2)** No open holes or breaks exist in surfaces of either the door or frame.
  - **(3)** Glazing, vision light frames, and glazing beads are intact and securely fastened in place, if so equipped.
  - **(4)** The door, frame, hinges, hardware, and noncombustible threshold are secured, aligned, and in working order with no visible signs of damage.
  - **(5)** No parts are missing or broken
  - **(6)** Door clearances do not exceed clearances listed in 4.8.4 and 6.3.1.7
  - **(7)** The self-closing device is operational; that is, the active door completely closes when operated from the full open position.
  - **(8)** If a coordinator is installed, the inactive leaf closes before the active leaf.
  - **(9)** Latching hardware operates and secures the door when it is in the closed position.
  - **(10)** Auxiliary hardware items that interfere or prohibit operation are not installed on the door or frame.
  - **(11)** No field modifications to the door assembly have been performed that void the label.
  - **(12)** Meeting edge protection, gasketing and edge seals, where required, are inspected to verify their presence and integrity.
  - **(13)** Signage affixed to a door meets requirements listed in 4.1.4

# Fire Door Inspections

13 points of verification

## (1) Labels are clearly visible and legible.

### – 4.2\* Listed and Labeled Products

- 4.2.1\* Listed items shall be identified by a label.
- 4.2.2 Labels shall be applied in locations that are readily visible and convenient for identification by the AHJ after installation of the assembly.



wood door and hollow metal frame



plastic laminate door



hollow metal frame

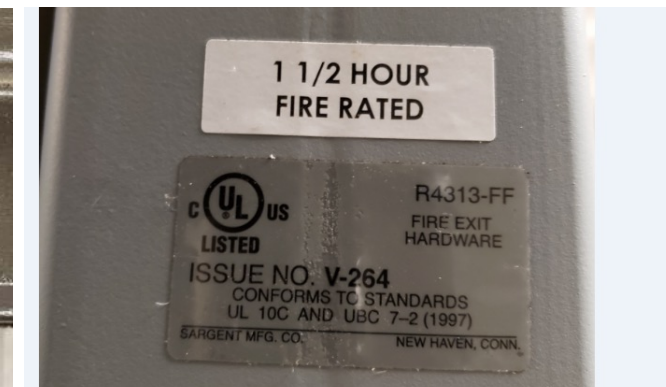

steel mullion

# Fire Door Inspections

## 13 points of verification

### How to read the label

Reading the label:

1. Country identifier
2. Certification mark
3. Country identifier
4. Fire rating
5. Test
6. Limitations
7. Manufacturer
8. Manufacturer's part number
9. Installation instructions
10. Serial number
11. Intertek part number
12. Special instructions

### INFORMATION FOUND ON A WARNOCK HERSEY LABEL

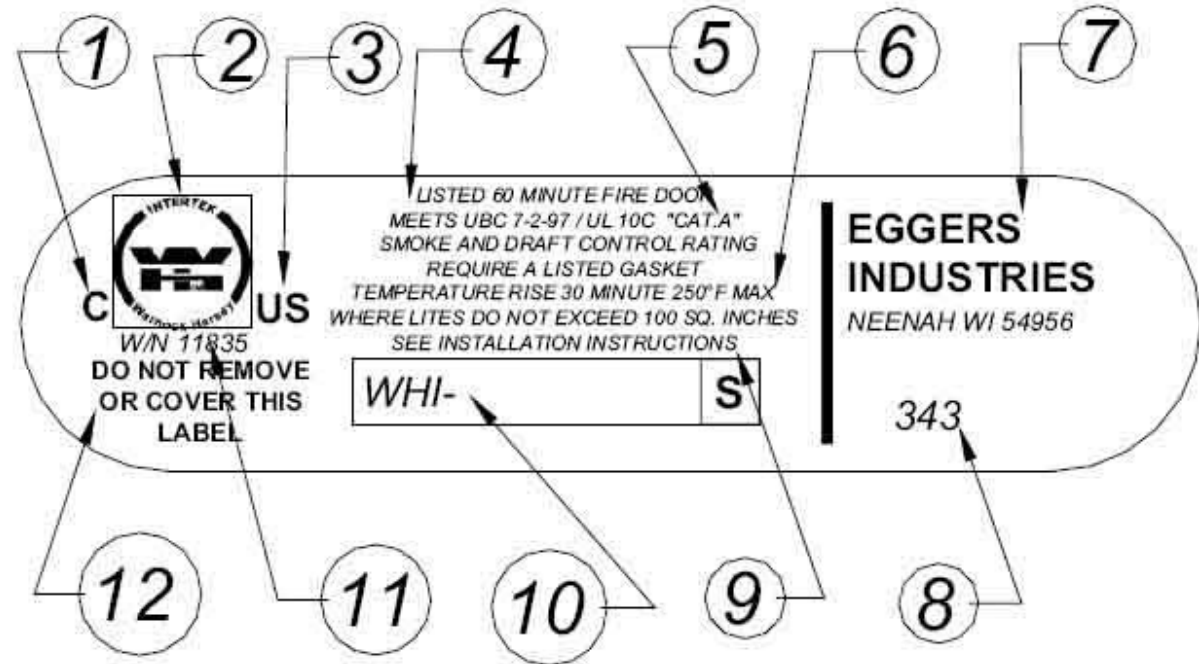

# Fire Door Inspections

## 13 points of verification

### Labels and listing for hardware components.

- Swinging Fire Doors with Builders Hardware
  - Marked with emblems and symbols
    - F, f, ff
    - UL
    - ETL
  - Embossed, stamped, or applied



*exit device*

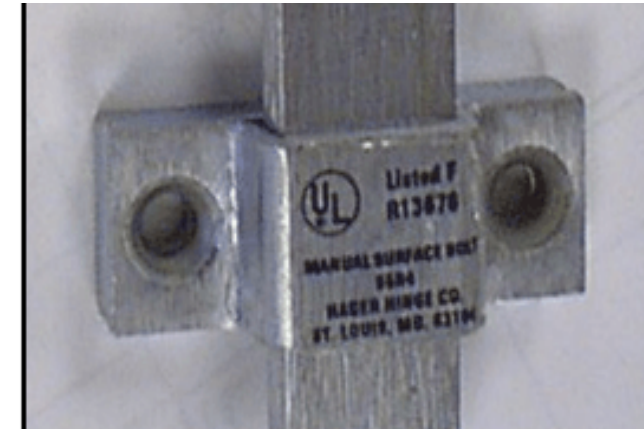

*door bolt*



*mortise lock*



*continuous hinge*

# Missing Fire Labels

- **NFPA 80 -2016**
- **5.1.4 Field Labeling**
- **5.1.4.1\*** Field labeling shall be performed only by individuals or companies that have been certified or listed, or by individuals or companies that are representatives of a labeling service that maintains periodic inspections of production of labeled equipment or materials and by whose labeling the manufacturer indicates compliance with appropriate standards or performance in a specified manner.

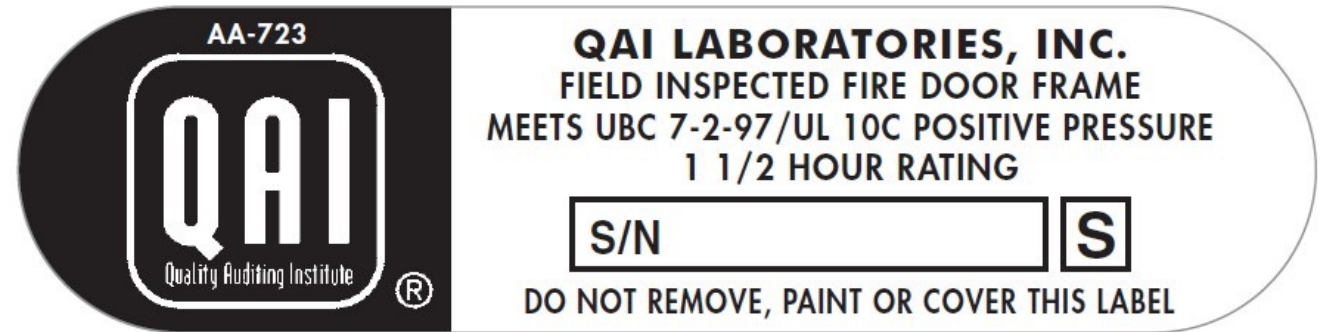

# Fire Door Inspections

## 13 points of verification

**(2) No open holes or breaks exist in surfaces of either the door or frame.**

- **5.5.7** When holes are left in a door or frame due to changes or removal of hardware or plant-ons, the holes shall be repaired by the following methods.
  - (1) Install steel fasteners that completely fill the holes.
  - (2) Fill the screw or bolt with the same material as the door or frame.



*relocated closer exposing original mounting holes*

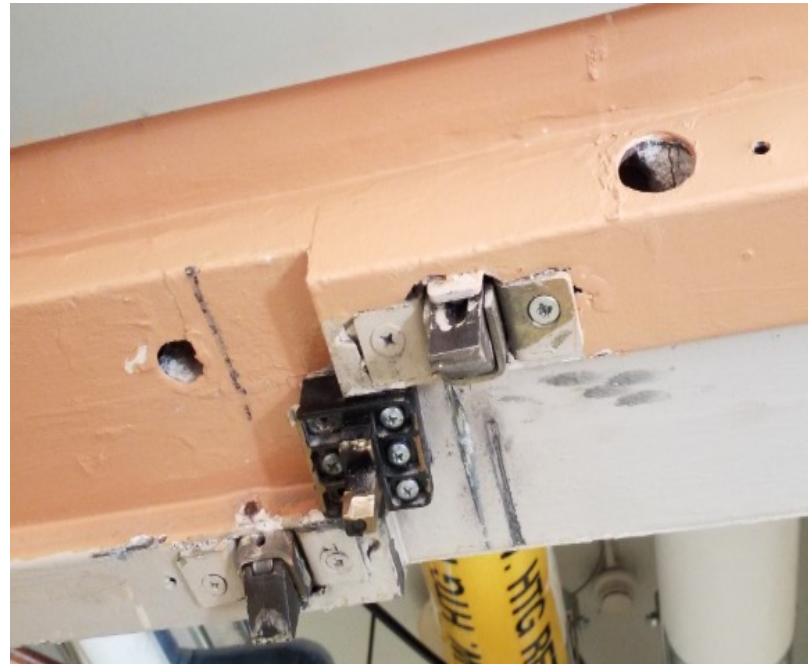

*frame head section of cross corridor doors*



*deadbolt never installed on opening*



*??? 9mm? in random, but uniform pattern*

# Fire Door Inspections

*13 points of verification*

**(3) Glazing, vision light frames, and glazing beads are intact and securely fastened in place, if so equipped.**

- **6.3.3.5** Only labeled fire protection glazing or fire resistance glazing shall be used to glaze light openings.



# Fire Door Inspections

## *13 points of verification*

**(4) The door, frame, hinges, hardware, and noncombustible threshold are secured, aligned, and in working order with no visible signs of damage.**

- **5.5.5** Where a fire door, frame, or any part of its appurtenances is damaged to the extent that it could impair the door's proper emergency function, the following actions shall be performed:
  - (1) The fire door, frame, door assembly, or any part of its appurtenances shall be repaired with labeled parts or parts obtained from the original manufacturer.
  - (2) The door shall be tested to ensure emergency operation and closing upon completion of the repairs.



*exit device trim*



*mortise lock*

# Fire Door Inspections

*13 points of verification*

**(5) No parts are missing or broken.**



*exit device*



*strike*



*removable mullion*

# Fire Door Inspections

*13 points of verification*

**(6) Door clearances do not exceed clearances listed in 4.8.4 and 6.3.1.7.**

– **4.8.4 Clearance**

– **4.8.4.1\*** The clearance under the bottom of a door shall be a maximum of  $\frac{3}{4}$ " in. (19mm).

– **6.3.1.7\* Clearances**

– **6.3.1.7.1** The clearances between the top and vertical edges of the door and the frame, and the meeting edges of doors swinging in pairs, shall be  $\frac{1}{8}$  in.  $\pm$   $\frac{1}{16}$  in. for steel doors and shall not exceed  $\frac{1}{8}$  in. for wood doors.



*mechanical room (wood door and hollow metal frame)*

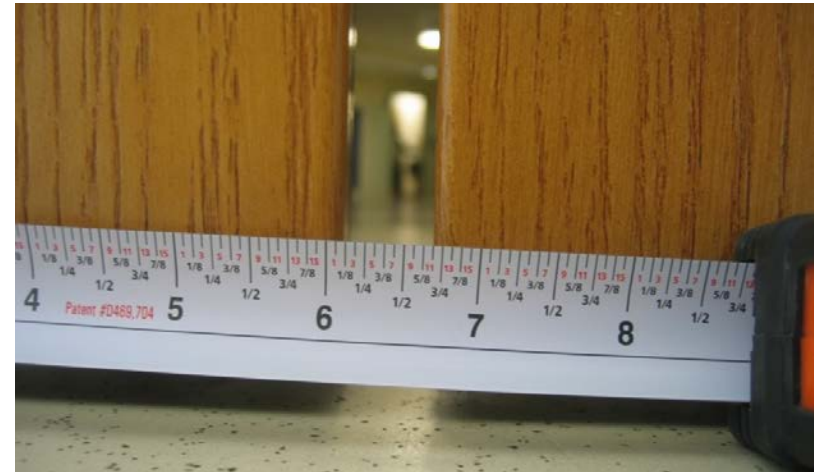

*cross corridor doors*

# Fire Door Inspections

*13 points of verification*

**(6) Door clearances do not exceed clearances listed in 4.8.4 and 6.3.1.7.**

**– Excessive gaps occur when:**

- Frames are installed incorrectly (alignment – plumb, square, level)
- Doors are improperly sized
- Hardware or flooring changes
- Door sags (improper hardware application, loose hardware, wear and tear, etc.)
- A building settles over time



# Excessive Door Gap Solutions

- Seals gaps and clearances that exceed the requirements of NFPA 80
- UL Certified for 90 minute fire doors
- No special preparation needed on existing doors
- Can be used on steel composite, hollow metal doors, wood and plastic-covered composite core doors

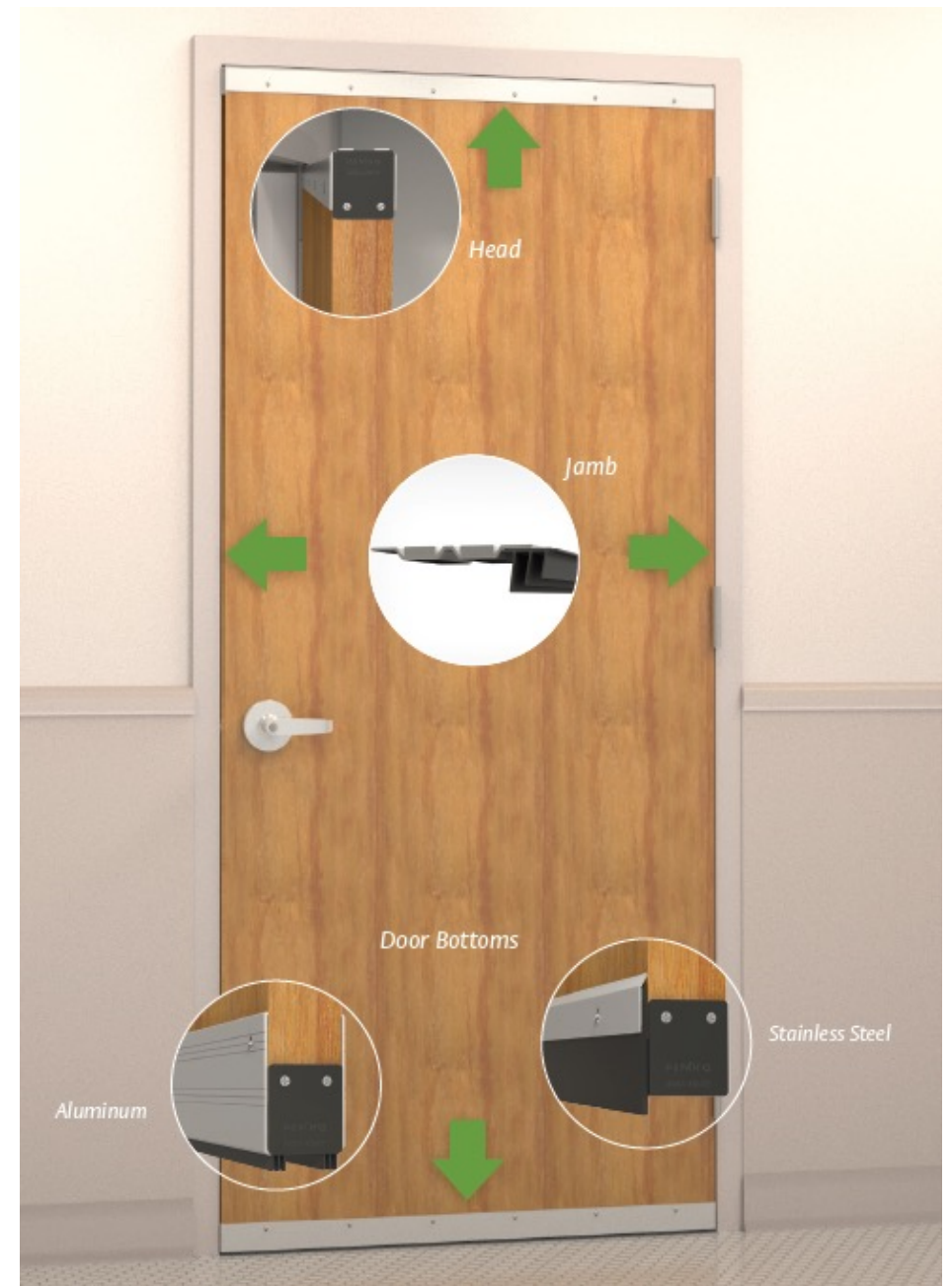

# Fire Door Inspections

*13 points of verification*

**(7) The self-closing device is operational; that is, the active door completely closes when operated from the full open position.**

**(8) If a coordinator is installed, the inactive leaf closes before the active leaf.**

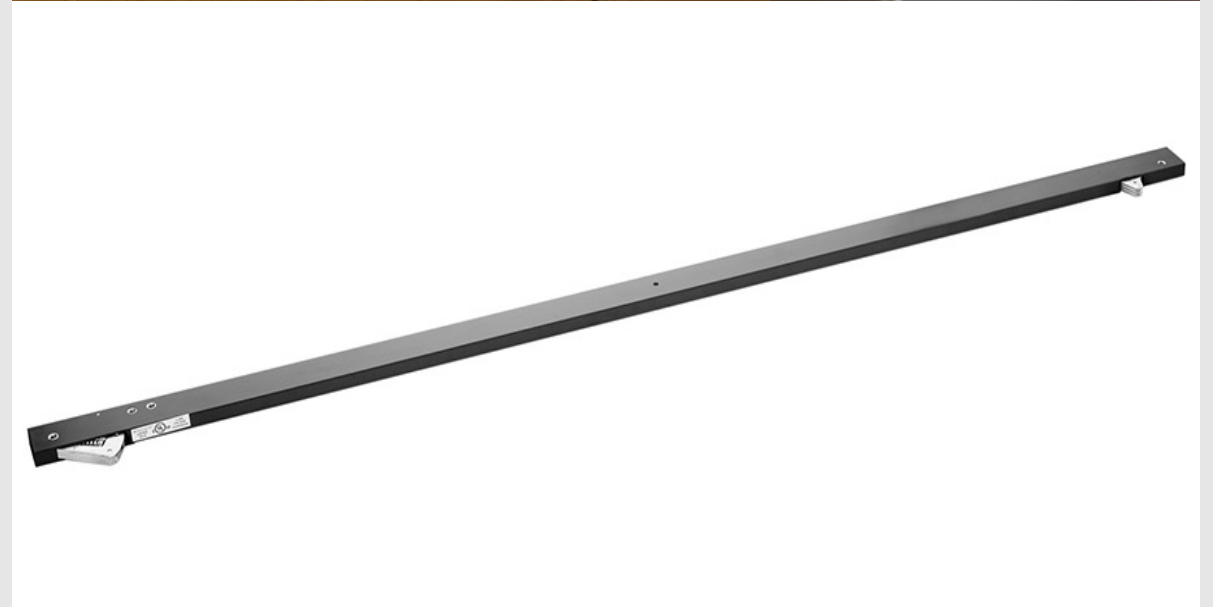

# Fire Door Inspections

*13 points of verification*

**(9) Latching hardware operates and secures the door when it is in the closed position.**

- **6.1.3 Operation of Doors** All swinging doors shall be closed and latched at the time of fire.
- **Common issues preventing closing and latching:**
  - Latching hardware is damaged or misaligned
  - Incorrect hardware application
  - Doors are propped open
  - Door closer is missing, damaged or incorrectly adjusted



*classroom wood door in hollow metal frame*

# Fire Door Inspections

*13 points of verification*

**(10) Auxiliary hardware items that interfere or prohibit operation are not installed on the door or frame.**

– **Common issues with auxiliary hardware:**

- Incorrect hardware application
- Hardware is not listed/labeled.
- Used to prop doors open



*exterior mechanical door*

# Fire Door Inspections

## *13 points of verification*

**(11) No field modifications to the door assembly have been performed that void the label.**

- **4.1.3.2** For jobsite preparation of surface applied hardware, function holes for mortise locks and holes for labeled viewers, a maximum  $\frac{3}{4}$  in. (19mm) wood and composite door undercutting, and protection plates (see 6.4.5) shall be permitted.
- **4.1.3.3** Surface applied hardware shall be applied to the door or frame without removing material other than drilling round holes to accommodate cylinders, spindles, similar operational elements, and through-bolts in doors
- **4.1.3.4** The holes described in 4.1.3.3 shall not exceed a diameter of 1 in. (25.4mm), with the exception of cylinders.



*electric strike with mortise lock*



*electric strike with cylindrical lock*

# Fire Door Inspections

*13 points of verification*

**(12) Meeting edge protection, gasketing and edge seals, where required, are inspected to verify their presence and integrity.**

**– Common issues gasketing:**

- Hardware is not listed/labeled.
- Incorrect modification during installation
- damage





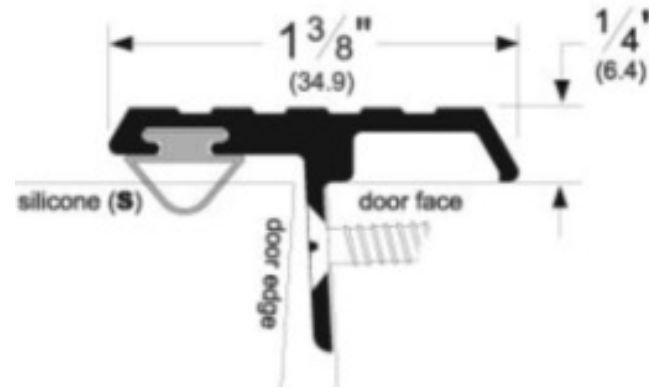





*fire/smoke gasketing*



*"T" astragal*

**Ratings**

-  Air Infiltration Tested
-  Intertek Testing (Warnock Hersey)
-  Sound Tested - ASTM E90
-  BHMA Certified
-  Smoke Tested - UL1784
-  Fire Rated - Edge Seals - UL10C - Positive Pressure
-  Underwriters Laboratory 4L10
-  GREENGUARD Gold Certified

**Ratings**

-  Air Infiltration Tested
-  Smoke Tested - UL1784
-  Fire Rated - UL10C - Positive Pressure
-  Underwriters Laboratory 4L10
-  GREENGUARD Gold Certified

# Fire Door Inspections

## *13 points of verification*

### **(13) Signage affixed to a door meets the requirements listed in 4.1.4.**

- **4.1.4.1** The total area of all attached signs shall not exceed 5 percent of the area of the face of the fire door to which they are attached .
- **4.1.4.2.1** Signs shall be attached to fire doors by use of an adhesive.
- **4.1.4.2.2** Mechanical attachments such a screws or nails shall not be permitted.
- **4.1.4.3** Signs shall not be installed on glazing material in fire doors.
- **Common issues with auxiliary hardware:**
  - Exceeds 5% of door surface area
  - Decorations
  - Signage on fire rated glazing



*office door off corridor*

# Fire Door Inspections

*"ASHE has contracted with the Center for Health Design (CHD) to research why the failure rate of fire doors in hospitals is as high as is being documented during accreditation surveys."*

- **Possible contributing factors:**
  - Inaccurate or lack of fire door inspection at time of construction
  - Inaccurate annual fire door inspections
  - Non-compliant field modifications to openings
  - Lack of regular maintenance program

## DOOR INSPECTION AND MAINTENANCE

Top reasons for LS.02.01.10 and LS.02.01.30 door failures

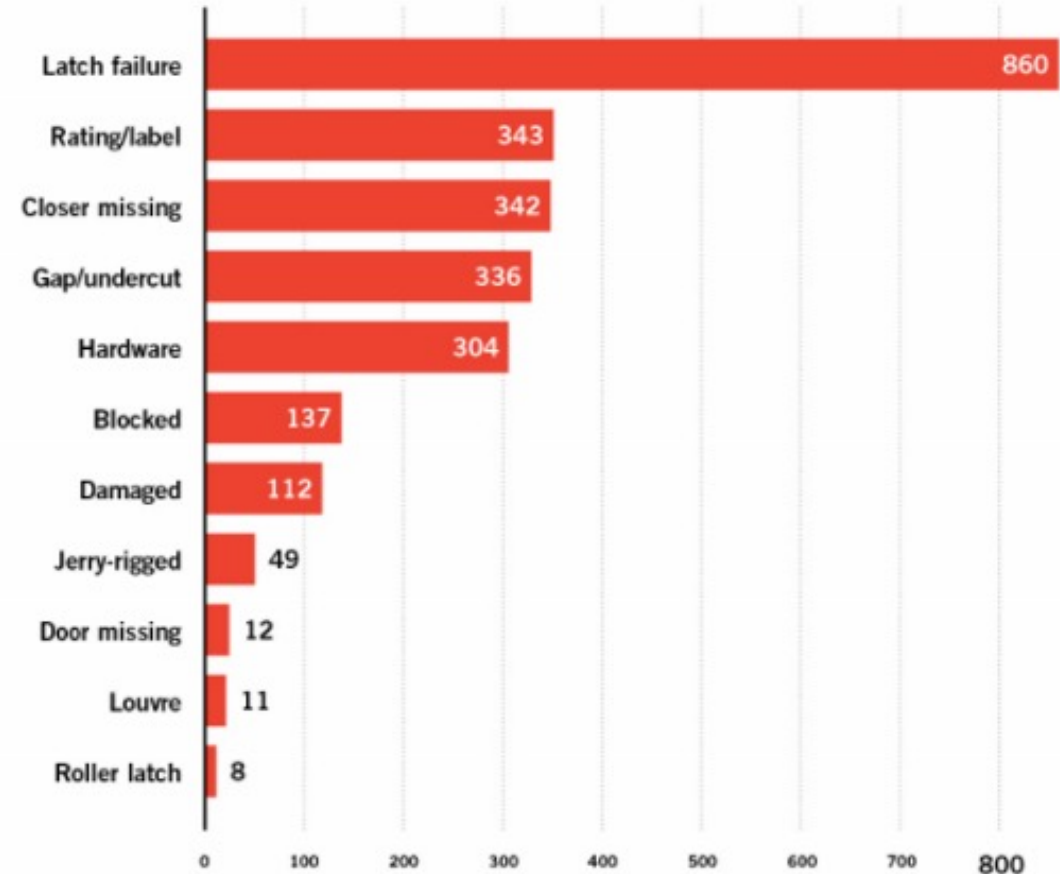

Joint Commission findings related to fire-door maintenance.

# NFPA 80 Reporting Requirements

- **5.2.2.4** A record of all inspections and testing shall be provided that includes, but is not limited to, the following information:
  - **(1)** Date of inspection
  - **(2)** Name of facility
  - **(3)** Address of facility
  - **(4)** Name of person(s) performing inspections and testing
  - **(5)** Company name and address of inspecting company
  - **(6)** Signature of inspector of record
  - **(7)** Individual record of each inspected and tested fire door assembly
  - **(8)\*** Opening identifier and location of each inspected and tested fire door assembly
  - **(9)\*** Type and description of each inspected and tested fire door assembly
  - **(10)\*** Verification of visual inspection and functional operation
  - **(11)** Listing of deficiencies in accordance with 5.2.3, Section 5.3, and Section 5.4

# NFPA 80 Record Keeping Requirements

## 5.2.2.2

- Unless a longer period is required by section 5.4, records shall be retained for a period of at least **3 years**.

## 5.2.2.3

- The records shall be on a medium that will survive the retention period. Paper or electronic media shall be permitted.

## INSPECTION CHECKLIST 2008

Date \_\_\_\_\_, 2008  
Pg. \_\_\_\_\_ of \_\_\_\_\_

BUILDING NAME \_\_\_\_\_

Door Number	Fire-Rating	Door Location	Compliant
			<input type="checkbox"/> YES <input type="checkbox"/> NO
Remarks:			

<b>FRAME</b> <input type="checkbox"/> Loose Frame <input type="checkbox"/> Damaged Frame <input type="checkbox"/> Rust-through on Frame <input type="checkbox"/> Missing Label <input type="checkbox"/> Frame is Out of Alignment <input type="checkbox"/> Incorrect Glass in Sidelight or Transom-light <input type="checkbox"/> Broken Glass in Sidelight or Transom-light <input type="checkbox"/> Missing Glazing Bead at Light(s) <input type="checkbox"/> Missing Glazing Bead Screw(s) <input type="checkbox"/> Improper Field Modification (Explain Modification) <input type="checkbox"/> Incorrect Hardware Preparation (Explain) <input type="checkbox"/> Unused Fastener Hole(s) in Frame <input type="checkbox"/> Other _____  <b>DOOR</b> <input type="checkbox"/> Missing Door(s) <input type="checkbox"/> Missing Label <input type="checkbox"/> Damaged Door(s) (e.g., Dented, Bent) <input type="checkbox"/> Rust-through on Door(s) <input type="checkbox"/> Delamination of Door Skin or Face <input type="checkbox"/> Incorrect Glass in Light(s) <input type="checkbox"/> Broken Glass in Light(s) <input type="checkbox"/> Light(s) is/are Too Large	<b>DOOR (cont.)</b> <input type="checkbox"/> Loose Light Kits <input type="checkbox"/> Missing Light Kit Screw(s) <input type="checkbox"/> Improper Field Modification (Explain Modification) <input type="checkbox"/> Incorrect Hardware Preparation (Explain) <input type="checkbox"/> Unused Fastener Hole(s) in Door(s) <input type="checkbox"/> Improper Plant-ons <input type="checkbox"/> Replace Door <input type="checkbox"/> Other _____  <b>OPERATIONAL TEST</b> <input type="checkbox"/> Door Does NOT Swing Freely <input type="checkbox"/> Door Does NOT Close Completely <input type="checkbox"/> Door Does NOT Security Latch <input type="checkbox"/> Electric Door Release Does NOT Allow Door to Close <input type="checkbox"/> Door Bottom Drags Against Floor Material <input type="checkbox"/> Door Rubs Against Frame <input type="checkbox"/> Edges of Paired Doors Overlap <input type="checkbox"/> Coordinator Does NOT Function Properly <input type="checkbox"/> Other _____	<b>HINGES/PIVOTS</b> <input type="checkbox"/> Missing Hinge(s) <input type="checkbox"/> Incorrect Hinge(s) <input type="checkbox"/> Loose Hinge(s) <input type="checkbox"/> Missing Screw(s) <input type="checkbox"/> Replace Hinge(s) <input type="checkbox"/> Other _____  <b>DOOR BOLTS</b> <input type="checkbox"/> Missing Top Flush Bolt <input type="checkbox"/> Missing Bottom Flush Bolt <input type="checkbox"/> Missing Strike (Top Bolt) <input type="checkbox"/> Missing Strike (Bottom Bolt) <input type="checkbox"/> Bottom Bolt does NOT Engage Strike <input type="checkbox"/> Missing Bolt Head (Top) <input type="checkbox"/> Missing Bolt Head (Bottom) <input type="checkbox"/> Missing Rub Plate(s) <input type="checkbox"/> Incorrect Type of Flush Bolt(s) <input type="checkbox"/> Other _____	<b>LOCKS</b> <input type="checkbox"/> Missing Lock <input type="checkbox"/> Incorrect Latch Bolt Throw <input type="checkbox"/> Non-fire Rated Latch Bolt <input type="checkbox"/> Latch Bolt Binds <input type="checkbox"/> Latch Bolt Missing <input type="checkbox"/> Loose Lever(s) or Knob(s) <input type="checkbox"/> Latch Bolt Does NOT Engage Strike <input type="checkbox"/> Missing Strike Plate <input type="checkbox"/> Missing Screw(s) <input type="checkbox"/> Missing Flush Bolt <input type="checkbox"/> Missing Flush Bolt Strike <input type="checkbox"/> Other _____  <b>FIRE EXIT HARDWARE</b> <input type="checkbox"/> Missing Fire Exit Device <input type="checkbox"/> Missing Latch Bolt Assembly (Top) <input type="checkbox"/> Missing Latch Bolt Assembly (Bottom) <input type="checkbox"/> Missing Strike(s) <input type="checkbox"/> Missing Vertical Rod (Top) <input type="checkbox"/> Missing Vertical Rod (Bottom) <input type="checkbox"/> Push Bar Does NOT Extend Halfway Across Door Width <input type="checkbox"/> Non-fire Rated Panic Hardware (Dogging) <input type="checkbox"/> Missing Lever or Knob	<b>FIRE EXIT HARDWARE (cont.)</b> <input type="checkbox"/> Other _____ <input type="checkbox"/> Missing Door Closer(s) <input type="checkbox"/> Leaking Door Closer(s) <input type="checkbox"/> Missing Arm(s) <input type="checkbox"/> Broken Arm(s) <input type="checkbox"/> Missing Closer(s) <input type="checkbox"/> Does NOT Close Door Completely <input type="checkbox"/> Missing Screw(s) <input type="checkbox"/> Missing Drop and/or Adapter Plate(s) <input type="checkbox"/> Hold-open Arm(s) <input type="checkbox"/> Missing Coordinator <input type="checkbox"/> Missing Carry Bar <input type="checkbox"/> Broken Coordinator <input type="checkbox"/> Broken Carry Bar <input type="checkbox"/> Overhead Hold-open (Surface or Concealed) <input type="checkbox"/> Other _____	<b>MISCELLANEOUS</b> <input type="checkbox"/> Missing Threshold/ Saddle <input type="checkbox"/> Incorrect Clearance (Top of Door to Frame) <input type="checkbox"/> Incorrect Clearance (Hinge Edge to Frame) <input type="checkbox"/> Incorrect Clearance (Lock Edge to Frame) <input type="checkbox"/> Incorrect Clearance (Door Bottom to Floor) <input type="checkbox"/> Incorrect Clearance (Between Doors) <input type="checkbox"/> Missing Astragal <input type="checkbox"/> Missing or Damaged Gasketing/Smoke Seal <input type="checkbox"/> Kick-down Door Holder <input type="checkbox"/> Door Wedge <input type="checkbox"/> Door Stop with Hold Open (Manual) <input type="checkbox"/> Protection Plate(s) too Large <input type="checkbox"/> Protection Plate(s) Missing screw(s) <input type="checkbox"/> Signage Too Large <input type="checkbox"/> Signage, Screwed/Nailed to Door <input type="checkbox"/> Other _____
--	---	---	--	--	--



A Program of the Door and Hardware Institute

("White" copy is ORIGINAL • "Pink" copy is DUPLICATE COPY • "Yellow" copy is INSPECTOR'S COPY)

© COPYRIGHT 2008 THE DOOR AND HARDWARE INSTITUTE. ALL RIGHTS RESERVED. Use of this inspection form without the express written consent of the Door and Hardware Institute is strictly forbidden.

FORM 4



# Fire Door Inspection Reporting

- Actionable reporting
- Complete record of opening
  - Detailed information on installed door, frame, hardware components
  - Images of opening from secured/unsecured sides
- Issues clearly identified
- Customizable link-outs to product collateral information
  - Default links to non-proprietary database of product catalogs

**Openings Studio™**

**ASSA ABLOY**  
Fire Door Inspection Report

**Level:** 1ST FLOOR      **Mark:** D1063B

**Description:** 6' 0" x 8' 0" x 1 3/4"

**Secure Side**



**Non-Secure Side**



**Hardware Set #: 13.0**

Qty	Type	Description
7	Hinge	(std weight)
1	Elec Hinge	(std weight)
1	Exit Device	(SVR, storeroom)
1	Exit Device	(SVR, storeroom)
1	Blank Cylinder	
1	Mortise Cylinder	
2	Surface Closer	
1	Threshold	
1	Gasketing	
2	Astragal	
2	Sweep	
2	Position Switch	
1	Card Reader	
1	Motion Sensor	
1	Power Supply	

**Hardware Set Notes:**

**Issue Comments:**

CL6: Closer not securley fastened  
Issue Status: Non-Compliant

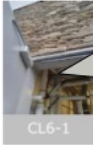

CL6-1

**Project:**

**Report Date:**

Page 41

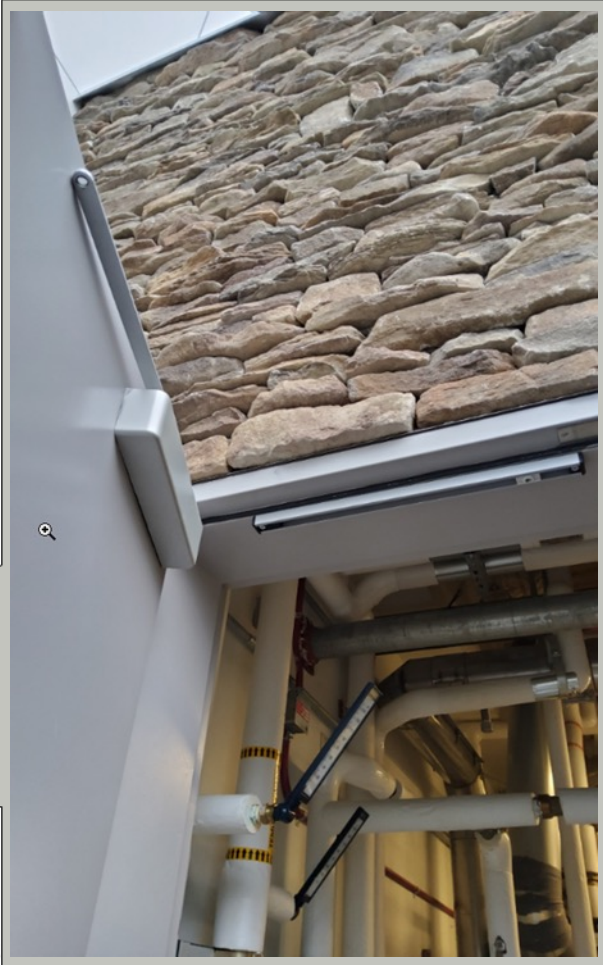

# Fire Door Inspection Reporting

- Actionable reporting
- Complete record of opening
  - Detailed information on installed door, frame, hardware components
  - Images of opening from secured/unsecured sides
- Issues clearly identified
- Customizable link-outs to product collateral information
  - Default links to non-proprietary database of product catalogs

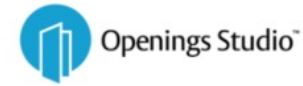

Level: 1ST FLOOR

Mark: D1063B

Description: 6' 0" x 8' 0" x 1 3/4"

**Norton**  
ASSA ABLOY

Page Revised Electronically 4/15

**2800ST SERIES**  
CAM ACTION DOOR CLOSER

STANDARD APPLICATIONS



**2800ST HINGE (PULL) SIDE OF DOOR**

- Maximum interior door width 54" (137cm).
- An auxiliary stop (by others) is suggested where severe conditions exist.
- 140° swing (trim permitting)

Note: Door openings to 160° can be achieved if an auxiliary door stop (by others) is installed to dead stop the door. Consult factory for details.

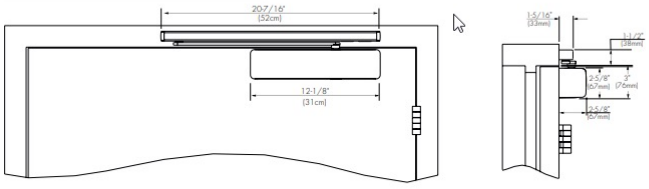

**PS2800ST STOP (PUSH) SIDE OF DOOR**

- Minimum frame reveal is 1-1/2" (13mm).
- An auxiliary door stop is suggested when severe conditions exist.
- 110° swing (trim permitting)

Note: Door openings up to 130° can be achieved if an auxiliary door stop (by others) is installed to dead stop the door. Consult factory for details.



NOTE: Contact factory for use on doors exceeding 250 lbs.

Part Description	Finish	Power	Manufacturer
TA2314 4-1/2" x 4-1/2"	US26D		McKinney
TA2314 4-1/2" x 4-1/2" QC12	US26D	⚡	McKinney
12 LC 8706 ETB	US32D		SARGENT
12 LC 56 8706 ETB	US32D	⚡	SARGENT
part number needed			Other
part number needed			ASSA High Security Locks
PS2800ST	689		Norton Door Controls
<b>Issue Code: CL6</b>			
270A			Pemko
S88BL			Pemko
329CN			Pemko
3452CNB			Pemko
2757L		⚡	Sentrol 12345
RP40		⚡	HID Global
XMS		⚡	Securitron
Central Power Supply by Security Integrator			

Opening Remarks:

Project:

Report Date:

[www.openingsstudio.com](http://www.openingsstudio.com) | 1-833-762-AAOS

Page 41 of 110

© ASSA ABLOY, All rights reserved

# Repairs

- **5.5 Maintenance**
- **5.5.1\*** Repairs shall be made, and defects that could interfere with operation shall be corrected without delay.
- Replacing worn out hardware
  - Hinges, locks/latches, door closers, gasketing, etc.
- Replacing broken glazing
- Tightening/replacing fasteners
  - Builders hardware requires special fasteners
- Filling unused fastener holes in doors and frames
  - Steel/stainless steel screws, fire door caulk
- Monitoring/adjusting door clearances
  - Steel shims, gap filling solutions
- Replacing small parts
  - Strike plates, end caps, covers, gasketing, etc.



# Managing Opening Maintenance

- Detailed inventory of openings
- Accurate identification of fire rated, smoke rated and egress doors
- Reporting capabilities
  - Meeting CMS and NFPA 80 requirements
  - Actionable for remediation
  - Record storage
- Tools to access opening data remotely or at the opening



# Design Standards

## VDG - HEALTHCARE (SARGENT)

Get ready to communicate standards faster with the ASSA ABLOY Virtual Design Guide.

To get started, click on an opening. >>

### Standards

Standard Openings

- AAOS - HS1 - Hardware Sets - p1
- AAOS - TO1 - Typical Openings - p1
- AAOS - TO2 - Typical Openings - p2
- AAOS - TO3 - Typical Openings - p3
- AAOS - E1 - Electrical - p1
- AAOS - E2 - Electrical - p2
- AAOS - E3 - Electrical - p3
- AAOS - DFT1 - Door/Frame Types - p1

### Guide Specs

Experience a safer and more open world

### HW Set 1.0 - Entry Pair

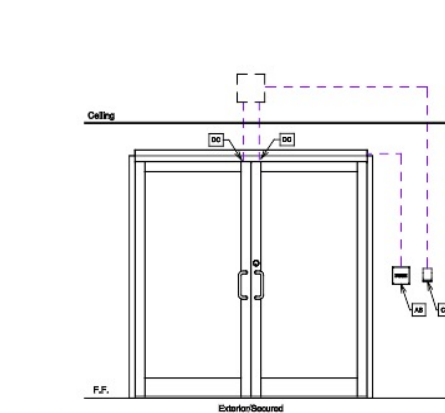

HW Set 1.0 - Entry Pair - Elevation Front - AAOS - Electrical 1/2" = 1'-0"

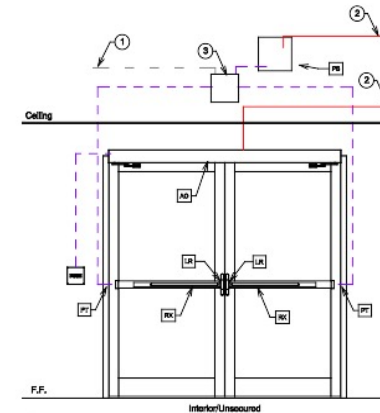

HW Set 1.0 - Entry Pair - Elevation Back - AAOS - Electrical 1/2" = 1'-0"

Application: Storefront Entry - Card Reader, Automatic Operators

DOOR HARDWARE MATERIAL LIST				
QTY	SYM	DESCRIPTION	MANUFACTURER	MODEL
1	L/R/RX	Exit Device (CVR, exit only)	SA	DG184 55 56 ADB410 ED
1	L/R/RX	Exit Device (CVR, right/left)	SA	DG184 55 56 ADB410 106
1	AO	Door Operator	BM	SW2000 Dual
2	PT	Electric Power Transfer	SU	EL-CEPT
2	DC	Door Control Switch	SU	DFR2-M-GY
1	CR	Card Reader	HG	RP40
2	AS	Actuator Switch	HO	505
1	PS	Power Supply	SU	AQD4-ACR2

- Notes:**  
Perimeter/meeting stile seals by frame/door supplier.
- DESCRIPTION OF OPERATION:**  
- Doors normally locked and latched.  
- Valid credential retracts act device latches, activates outside door switch. Pressing door switch activates operators.  
- Pressing inside door switch retracts latches, activates operators.  
- Free egress at all times.  
- Request-to-exit switch in push rail of exit device shunts alarm.  
- In case of power loss, doors are locked and latched. Operators are inactive.
- KEYED NOTES:**  
1 To Access Control Panel  
2 To Source Power  
3 Junction box by Division 26

### HW Set 3.0 - Rated Cross Corridor Pair - Auto Oper



### HW Set 4.0 - F

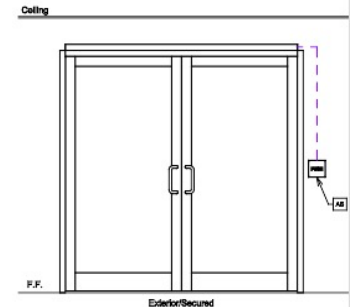

HW Set 2.0 - Vestibule Pair - Elevation Front - AAOS - Electrical 1/2" = 1'-0"

Application: Storefront Pair - Push/Pull, Automatic Operators

DOOR HARDWARE MATERIAL LIST				
QTY	SYM	DESCRIPTION	MANUFACTURER	MODEL
1	AO	Door Operator	BM	SW2000 Dual
2	AS	Actuator Switch	HO	505

- Notes:**  
Perimeter/meeting stile seals by frame/door supplier.
- DESCRIPTION OF OPERATION:**  
- Doors normally closed, push/pull manual operation.  
- Pressing outside or inside door switch activates operators.  
- Free egress at all times.
- KEYED NOTES:**  
2 To Source Power

**Q&A**

# Fire Door Inspections...



# Reporting...



# Remediation...

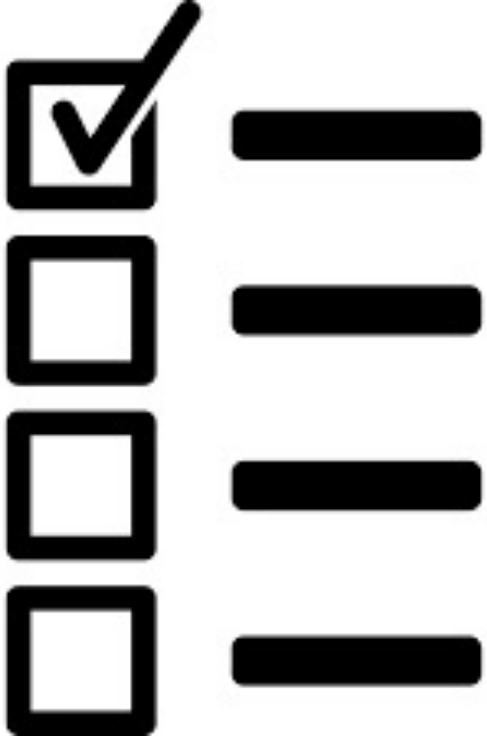

# Design Standards...

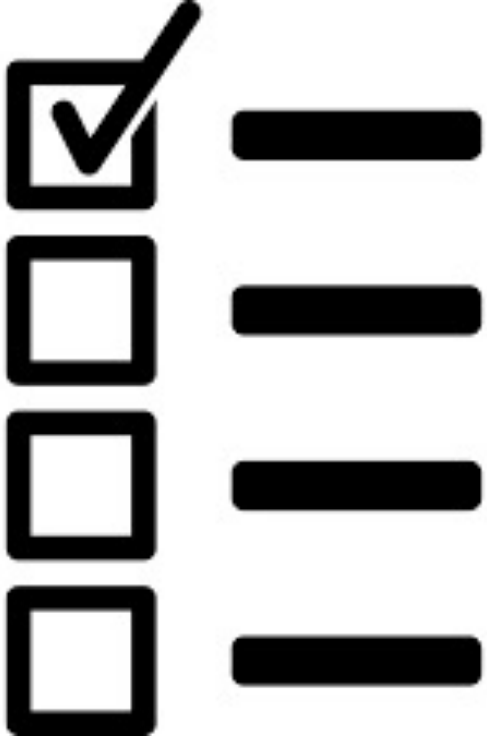

# Openings Studio™ Professional Services

Tom Morgan, AHC, FDAI

Director Business Development - Healthcare

Thomas.Morgan@assaabloy.com

(814) 923-2794

Ryan McLachlan, AHC, CFDAI, CM-BIM

Manager - Openings Studio Building Technologies

Ryan.McLachlan@assaabloy.com

(262) 825-3089

